

73.6V | 96Ah | Li-FePO4



E-MMORTAL AUTOMOTIVES

E-MMORTAL AUTOMOTIVES



# E-MMORTAL LITHIUM ION BATTERY

#ETERNAL\_FLOW\_OF\_ENERGY

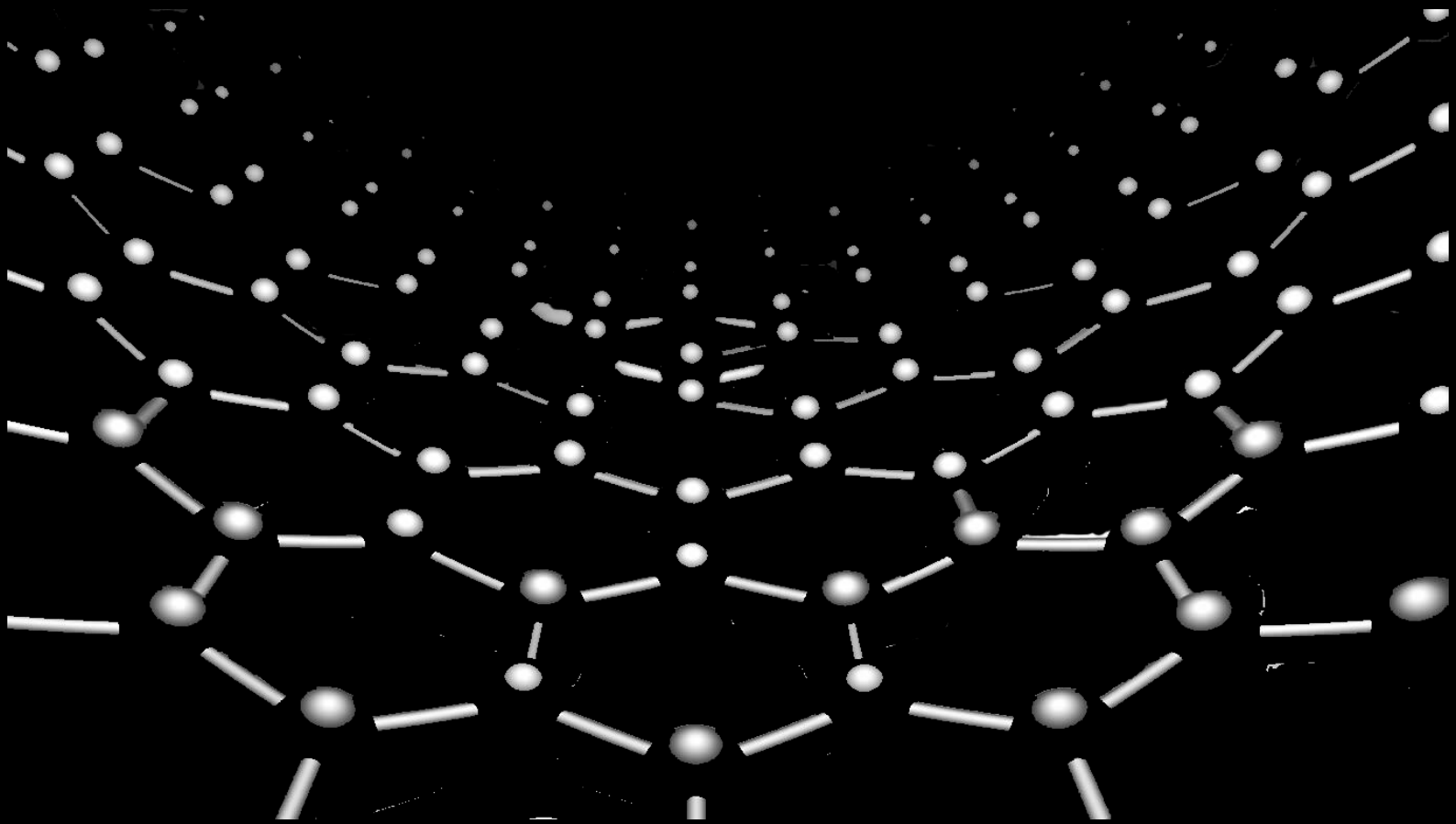

# BATTERY CONFIGURATION

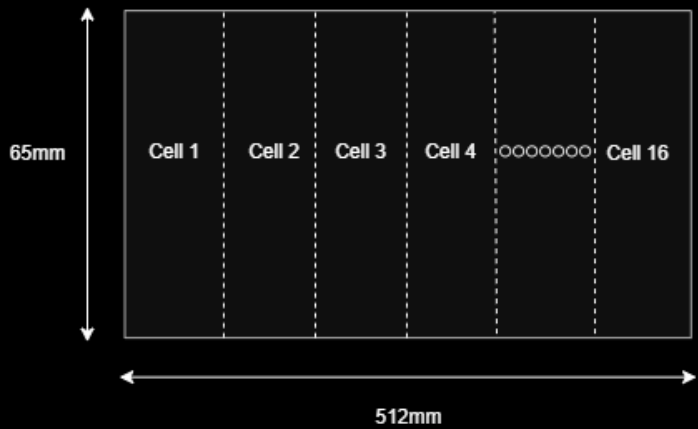
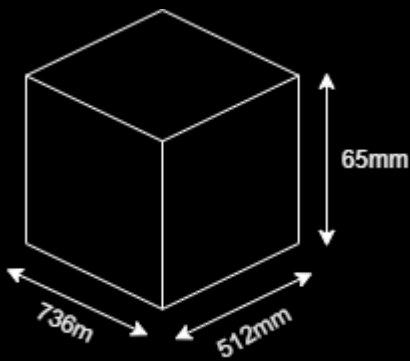
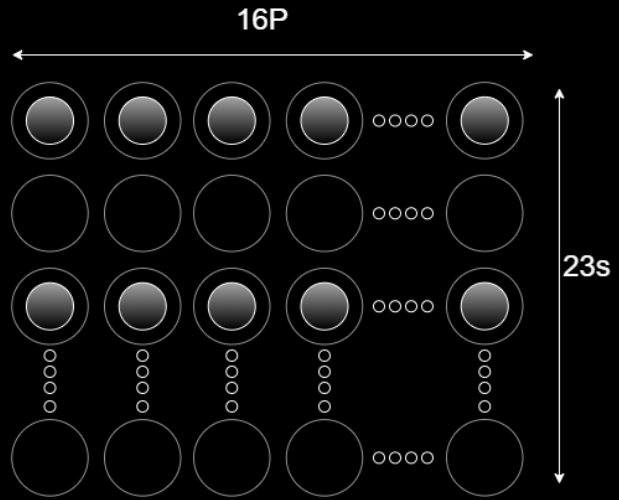
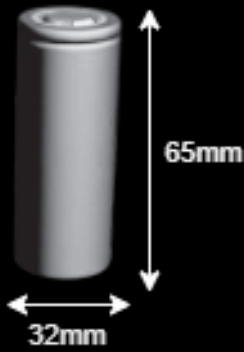

## Test Results:

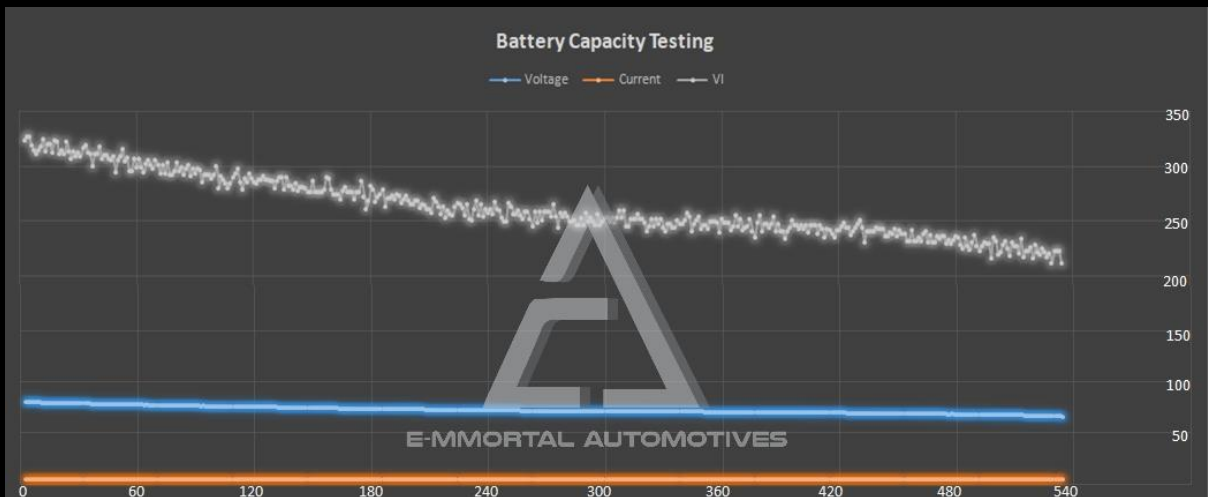

# SPECIFICATION

Description	Technical Specification	Remark
Nominal Capacity	96 Ah	Capacity according to standard charge and discharge.
Nominal Voltage	73.6 V	The average value of working voltage during the whole discharge process.
Nominal Wattage	7065.3Wh	
Type of Cell	Cylindrical	Part No. 32700
Capacity of Individual Cell	3.2V – 6000mAh	A Grade Cell with IR < 9mΩ.
Configuration	23S-16P	23 in series and 16 in parallel.
Charge Current	Up to 19.2A	Constant charge.
Discharge Current	Up to 19.2A	Constant discharge.
Peak Discharge	Up to 180A	Peak discharge for 3 sec.
Charge Cut-off Voltage	83.95V	Protected with balancing BMS.
Discharge Cut-off Voltage	64.4V	Protected with balancing BMS.
Working Temperature (Charging)	0-40°C	Under constant charge.
Working Temperature (Discharging)	0-40°C	Under constant discharge.
Weight	55KG	Approx.
Dimensions (Approx.)	Length(mm)	736mm
	Width(mm)	512mm
	Height(mm)	65mm
Cycle Life	≥2000	
Storage Temperature	1-3 Months	20-45°C
	3-6 Months	20-35°C
Battery (LCV)	Provided	
Battery (HCV)	Provided	
Battery Reverse Protection	Provided	
Packing Type	PVC material	PVC material
Output Cable	Provided	8 sq. mm

## E-mmortal Automotives Pvt. Ltd.



emmortalautomotives.com



info@emmortalautomotives.com



+91 90288 12136



ASM-03, Ashwin Nagar Service Rd, Ashwin Nagar, Nashik, Maharashtra 422009.